

The TIDAL™ 1.50m diameter Pillar buoy features a large visual and radar signature making it the ideal replacement for larger legacy buoys. The low draft hull design is optimized to provide stability and excellent performance in current. It is typically used as a channel marker, cautionary buoy or regulatory buoy in ports, inland waterways and coastal applications.

KEY FEATURES

- Rugged Modular Polyethylene Construction
- Excellent Visual and Radar Signature
- 316 Grade Stainless Steel Lifting & Mooring
- Standard and Optional Items
- 100% Recyclable after a long service life

MANUFACTURED TO LAST

Virgin colour compounded UV-20 polyethylene designed and tested to provide long-lasting colour fade and impact resistance. The lifting / mooring assembly and all fasteners and inserts are 316 grade stainless steel to minimize maintenance.

EXCELLENT RADAR SIGNATURE

The tower section contains a large internal radar reflector that boasts an industry leading 55 m² RCS (avg) that Coast Guard clients have confirmed has a 2+ NM range. The proprietary system used to secure the reflector also allows for its re-use.

VERSATILE

The low-draft hull design combined with a maximum mooring mass capacity of 500 kg (air) allow the buoy to be used in shallow water, high current applications and even deep water.

COLOUR CONFIGURATION

Available to meet the requirements of all IALA Colour / Configuration Recommendations with top marks and self-contained lanterns.

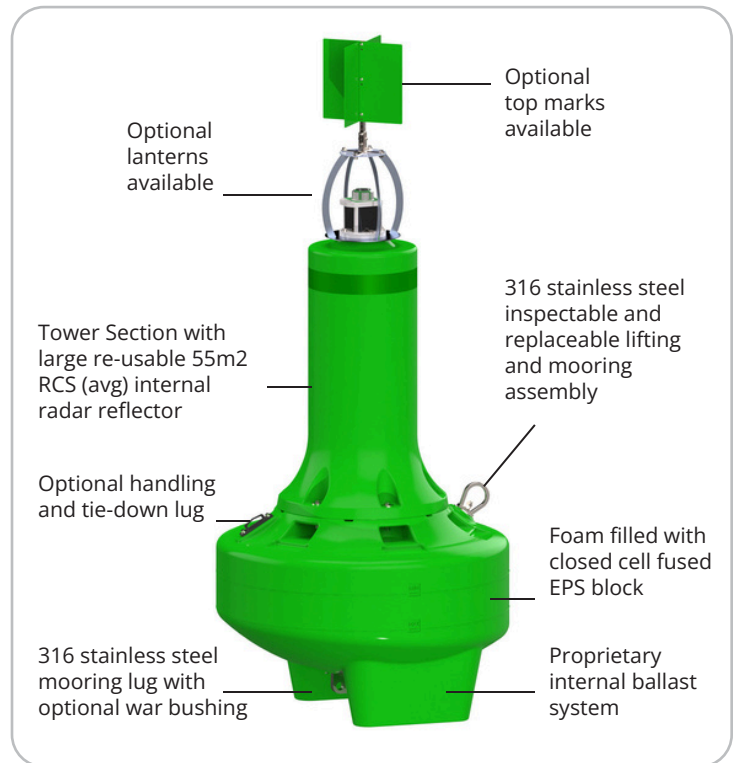

RECYCLING AND REUSE

All TIDAL™ buoys are manufactured solely with materials that are readily recyclable; items like the radar reflector are designed and secured so they can be re-used. Call to discuss how you or TIDAL™ can recycle your buoys.



GENERAL SPECIFICATIONS

Diameter	58 in	1.47 m
Height	95 in	2.41 m
Mass	633 lbs	287 kg
Hull Floatation Volume	12.6 cu ft	1.17 m ³
Submergence	85.2 lbs / in.	17.0 kg/cm

PERFORMANCE SPECIFICATIONS

Focal Plane Height (at Min. Mooring Mass)	86 in	2.19 m
Visible Height (at Min. Mooring Mass)	113 in	2.87 m
Draught (at Min. Mooring Mass)	21 in	0.53 m
Reserve Buoyancy (at Maximum Mooring Mass)	926 lbs	420 kg
Min. Mooring Mass (Air Weight)	220 lbs	100 kg
Max. Mooring Mass (Air Weight)	1,102 lbs	500 kg
Visual Area / Surface (at Max Visible Height)	37.7ft ²	3.50 m ²
Max. Distance of Recognition (at Max. Visible Height)	2.04 NM	3.78 km
Internal Radar Reflector (RCS: Peak / Average over 360°)	230 m ² / 55 m ²	
Radar Range	1.75 NM	3.24 Km

MATERIAL SPECIFICATIONS

Topmark	Conical topmark available	
Tower Structure	Virgin MDPE with UV20 protection package	
Buoy Hull	Virgin MDPE with UV20 protection package	
Wall Thickness	1/2 in	12 mm
Foam Filling	Closed cell EPS fused in situ block	
Lifting and Mooring Structure	316 stainless steel	
Safe Working Load (SWL)	2,205 lbs	1000 kg
Colours	Compliance with IALA Recommendation R0108	
IALA Compliance Testing	Independent laboratory test results available	
Colourfastness Test Procedure	Xenon Arc Accelerated Weathering per ASTM D-2565	
Colourfastness Testing	Independent test results available per ASTM D-2244	
Product Life Expectancy	15 to 20 years	
Warranty	5 years	

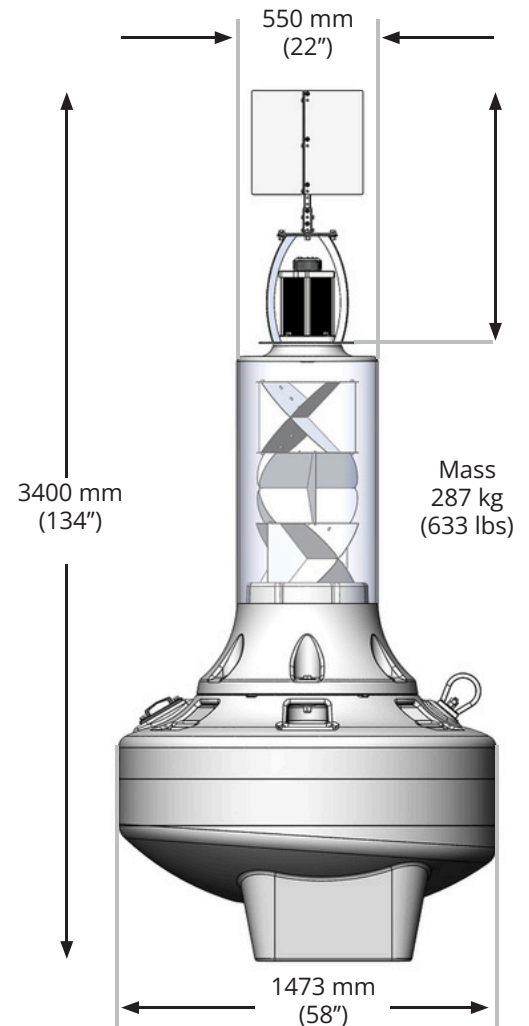

Mooring Line Design

- Mooring design to optimize the performance of each buoy.
- Advanced 3D dynamic analysis of the mooring line and buoy.
- Supply of custom mooring lines with proven components.
- Catenary, inverse-catenary, chain, and synthetics.

Our advanced modelling software can perform dynamic analysis of the interaction between the mooring line and the buoy in normal "operating" conditions to assess and optimize buoy performance. Importantly, this dynamic analysis is also used to assess performance across a range of "survival" conditions.



We carry a wide range of self-contained and externally powered lights for navigation buoys from world leaders such as Sabik, Sealite, Ekta, and Vega.

Depending on the size and use of the buoy, we offer options such as AIS Type I or Type II, Remote Monitoring & control, and on-board solar power systems.

PERFORMANCE SUMMARY

